

Please check the examination details below before entering your candidate information

Candidate surname

Other names

**Pearson Edexcel
International GCSE**

Centre Number

--	--	--	--	--

Candidate Number

--	--	--	--	--

Thursday 7 January 2021

Morning (Time: 1 hour 30 minutes)

Paper Reference **4MB1/01**

Mathematics B

Paper 1



You must have: Ruler graduated in centimetres and millimetres, protractor, pair of compasses, pen, HB pencil, eraser, calculator. Tracing paper may be used.

Total Marks

Instructions

- Use **black** ink or ball-point pen.
- **Fill in the boxes** at the top of this page with your name, centre number and candidate number.
- Answer **all** questions.
- Answer the questions in the spaces provided
– *there may be more space than you need.*
- **Calculators may be used.**

Information

- The total mark for this paper is 100.
- The marks for **each** question are shown in brackets
– *use this as a guide as to how much time to spend on each question.*

Advice

- Read each question carefully before you start to answer it.
- Check your answers if you have time at the end.
- Without sufficient working, correct answers may be awarded no marks.

Turn over ►

P66294A

©2021 Pearson Education Ltd.

1/1/1/



P 6 6 2 9 4 A 0 1 2 4



Pearson

Answer all TWENTY SIX questions.

Write your answers in the spaces provided.

You must write down all the stages in your working.

- 1 Without using a calculator and showing all your working, work out

$$5\frac{5}{8} - 3\frac{3}{4}$$

Give your answer as a mixed number in its simplest form.

.....
(Total for Question 1 is 2 marks)

- 2 Some students at a school are asked the following question

“Did you walk to school today?”

52% of the students asked are in Year 7 and the rest of the students asked are in Year 8.

20% of the students asked are Year 8 students who walked to school.

42% of the students asked did not walk to school.

Find as a percentage of all students asked, those who are in Year 7 and did not walk to school.

..... %
(Total for Question 2 is 2 marks)



- 3 Each interior angle of a regular polygon is 176°

Calculate the number of sides of the polygon.

.....
(Total for Question 3 is 2 marks)

- 4 $Q = 10 - At$

Work out the value of Q when $A = -2$ and $t = 3$

$Q =$

(Total for Question 4 is 2 marks)

- 5 Given that

$$\begin{pmatrix} -4 & x \\ y & 1 \end{pmatrix} + x \begin{pmatrix} 3 & 1 \\ 0 & -1 \end{pmatrix} = \begin{pmatrix} x & 4 \\ y & -1 \end{pmatrix}$$

find the value of x .

$x =$

(Total for Question 5 is 2 marks)



6 Here are four numbers written in order of size.

$$1.5 \quad 2 \quad p \quad 19.5$$

The mean of the four numbers is three times the median of the four numbers.

Find the value of p .

$$p = \dots\dots\dots$$

(Total for Question 6 is 3 marks)

DO NOT WRITE IN THIS AREA

DO NOT WRITE IN THIS AREA

DO NOT WRITE IN THIS AREA



DO NOT WRITE IN THIS AREA

DO NOT WRITE IN THIS AREA

DO NOT WRITE IN THIS AREA

7 Here is hexagon $ABCDEF$.

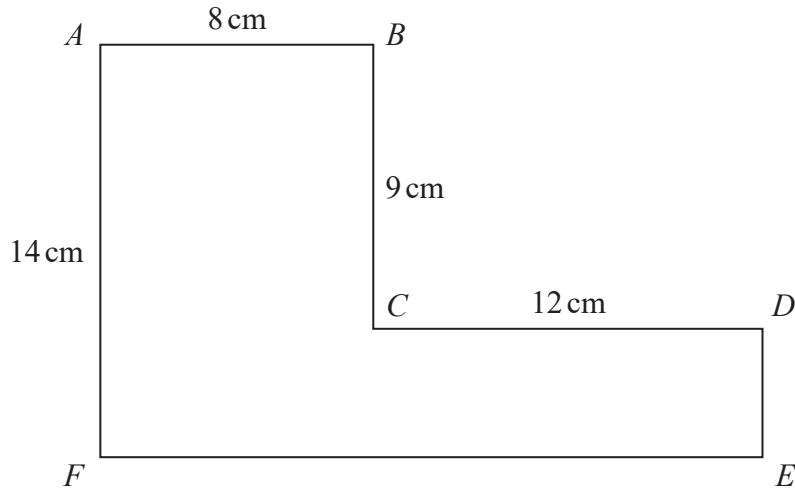

Diagram **NOT** accurately drawn

All the corners of $ABCDEF$ are right angles.

$$AB = 8\text{ cm} \quad AF = 14\text{ cm} \quad BC = 9\text{ cm} \quad CD = 12\text{ cm}$$

Calculate the area, in cm^2 , of $ABCDEF$.

..... cm^2

(Total for Question 7 is 3 marks)



8 Paul is carrying out an investigation into people's wages in the United Kingdom.

Paul asks two of his friends, Abdul and Sue, about the pay rise each received in the last year.

Abdul says that he has had a 5% pay rise in the last year.

Sue says that she has had a 7% pay rise in the last year.

Paul says that, in the last year, Sue's wages have risen by more than Abdul's wages.

(a) Explain why Paul might not be correct.

(1)

Paul has also read an article about the National Minimum Wage in the United Kingdom. The article says that, from April 2017 to April 2018, the national minimum hourly wage increased by 4.4% to £7.83

(b) Find the value of the National Minimum Wage before this increase.

£

(2)

(Total for Question 8 is 3 marks)



9

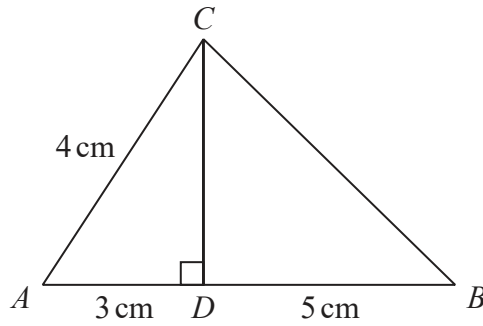

Diagram **NOT** accurately drawn

The diagram shows triangle ABC .

The point D lies on AB such that $\angle ADC = 90^\circ$

$$AC = 4 \text{ cm} \quad AD = 3 \text{ cm} \quad BD = 5 \text{ cm}$$

Calculate the size, in degrees to one decimal place, of $\angle ABC$.

..... ◦

(Total for Question 9 is 3 marks)



10 The n th term of a sequence is a_n where $a_n = \frac{2n^2 + 3n + 1}{2n + 2}$

By simplifying the expression for a_n or otherwise, explain why no term in the sequence is an integer.

Show algebraic working and clearly explain your reasoning.

(Total for Question 10 is 3 marks)

11 (a) Factorise $x^2 - 1$

.....
(1)

p and q are integers greater than 260 000 and $p < q$

(b) Find the value of p and the value of q such that $pq = 2^{36} - 1$

$p =$

$q =$

(2)

(Total for Question 11 is 3 marks)



DO NOT WRITE IN THIS AREA

DO NOT WRITE IN THIS AREA

DO NOT WRITE IN THIS AREA

12 The density, d grams/cm³, of an object of mass m grams and volume V cm³ is given by the formula

$$d = \frac{m}{V}$$

$m = 2800$ to the nearest 10
 $V = 1600$ to 3 significant figures.

Calculate the lower bound, to 3 significant figures, of d .
Show your working clearly.

.....
(Total for Question 12 is 3 marks)



13 Without using your calculator and showing all your working, express

$$\frac{\sqrt{13} + \sqrt{11}}{\sqrt{13} - \sqrt{11}}$$

in the form $a + \sqrt{b}$ where a and b are integers.

.....
(Total for Question 13 is 3 marks)

DO NOT WRITE IN THIS AREA

DO NOT WRITE IN THIS AREA

DO NOT WRITE IN THIS AREA



DO NOT WRITE IN THIS AREA

DO NOT WRITE IN THIS AREA

DO NOT WRITE IN THIS AREA

14 Jill travels to work either by car or by train.

Each day that Jill travels to work, the probability that she travels to work by train is 0.1

On a day that Jill travels to work by train, the probability that she will be late for work is 0.05

On a day that Jill travels to work by car, the probability that she will be late for work is 0.01

On a randomly chosen day that Jill travels to work, she is late for work.

Find the probability that Jill travelled to work by train on that day.

.....
(Total for Question 14 is 3 marks)



15 (a) Simplify $4x - 3y + x + 5y$

.....
(2)

(b) Simplify $2a^3 \times 4a^3$

.....
(2)

(Total for Question 15 is 4 marks)

16 (a) Factorise fully $10ab - 24a^2$

.....
(2)

(b) Factorise $p^2 + 10p - 24$

.....
(2)

(Total for Question 16 is 4 marks)



DO NOT WRITE IN THIS AREA

DO NOT WRITE IN THIS AREA

DO NOT WRITE IN THIS AREA

17 Given that $a = 2.1 \times 10^{56}$ and $b = 8 \times 10^{54}$

- (a) calculate ab
Give your answer in standard form.

.....
(2)

Given that $a + b = k \times 10^n$ where k and n are integers,

- (b) find the smallest value of k and the corresponding value of n

$k =$

$n =$

(2)

(Total for Question 17 is 4 marks)



18 Solve the simultaneous equations

$$5x + 3y = 2$$

$$3x - 8y = 4$$

Show clear algebraic working.

$$x = \dots\dots\dots$$

$$y = \dots\dots\dots$$

(Total for Question 18 is 4 marks)

DO NOT WRITE IN THIS AREA

DO NOT WRITE IN THIS AREA

DO NOT WRITE IN THIS AREA



19 $f(x) = x^3 + ax - 3$ where a is an integer.

$(x - 3)$ is a factor of $f(x)$

(a) Use the factor theorem to show that $a = -8$

(2)

Given that $f(x) = (x - 3)Q(x)$ where $Q(x)$ is a quadratic expression in x

(b) find $Q(x)$

$Q(x) = \dots\dots\dots$
(2)

(Total for Question 19 is 4 marks)



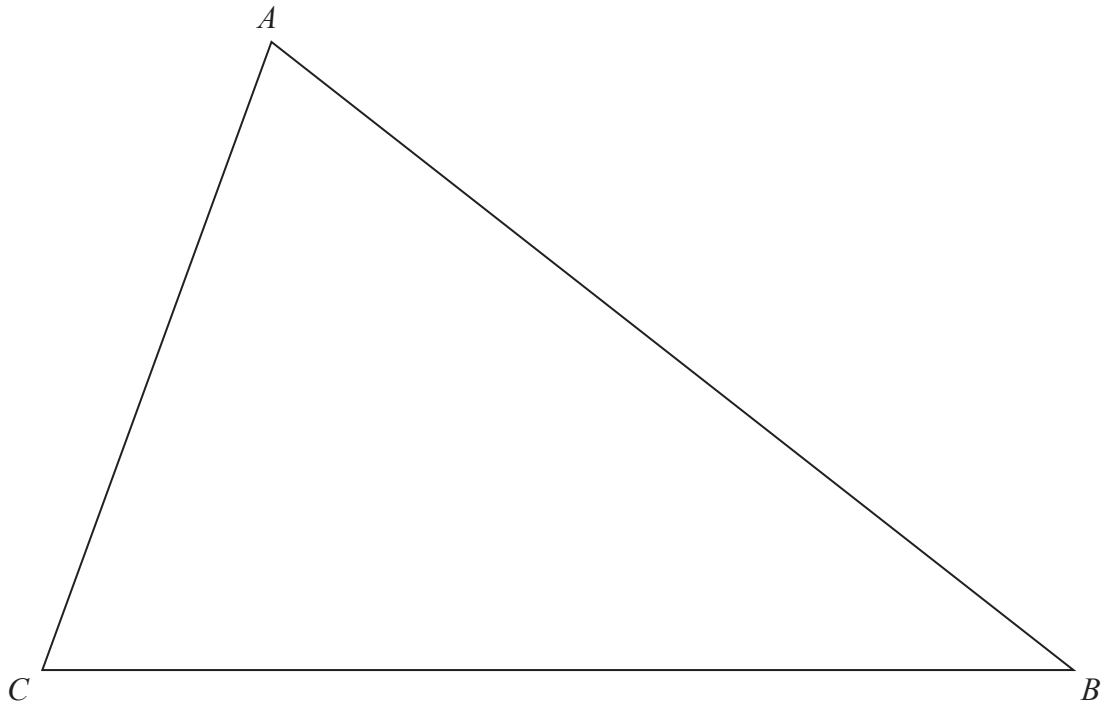

The diagram shows triangle ABC .

Showing all your construction lines, construct

- (a) the perpendicular bisector of AB , (2)
- (b) the bisector of $\angle ACB$. (2)

The region R consists of all the points inside the triangle that are closer to A than to B and closer to BC than to AC .

- (c) Show, by shading, the region R .
Label the region R . (1)

(Total for Question 20 is 5 marks)



Diagram **NOT** accurately drawn

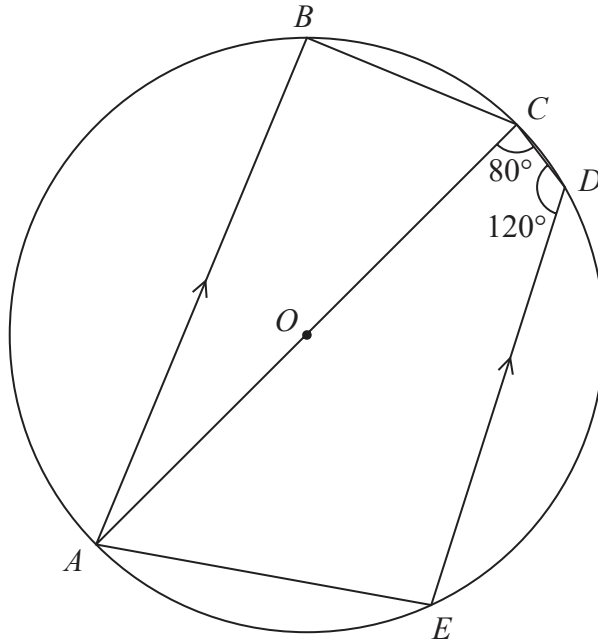

The diagram shows the circle $ABCDE$ with centre O .
 AC is the diameter of the circle.
 AB is parallel to ED .

$$\angle ACD = 80^\circ \qquad \angle CDE = 120^\circ$$

Giving your reasons, find the size, in degrees, of $\angle ACB$.

$$\angle ACB = \dots\dots\dots^\circ$$

(Total for Question 21 is 5 marks)



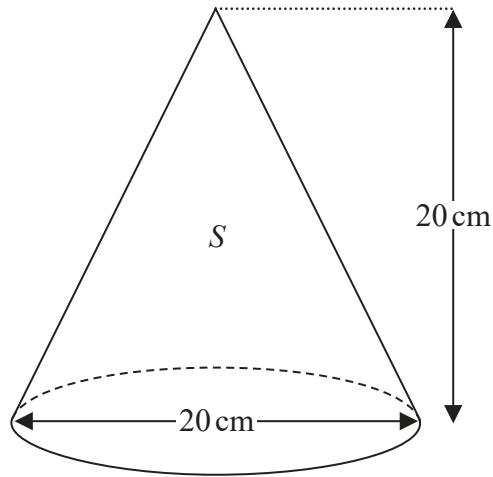

Diagram **NOT**
accurately drawn

DO NOT WRITE IN THIS AREA

DO NOT WRITE IN THIS AREA

DO NOT WRITE IN THIS AREA

The diagram above shows a right circular solid cone S with base diameter 20 cm and height 20 cm.

(a) Calculate the volume, in cm^3 to 3 significant figures, of S .

..... cm^3
(2)



DO NOT WRITE IN THIS AREA

DO NOT WRITE IN THIS AREA

DO NOT WRITE IN THIS AREA

Diagram **NOT**
accurately drawn

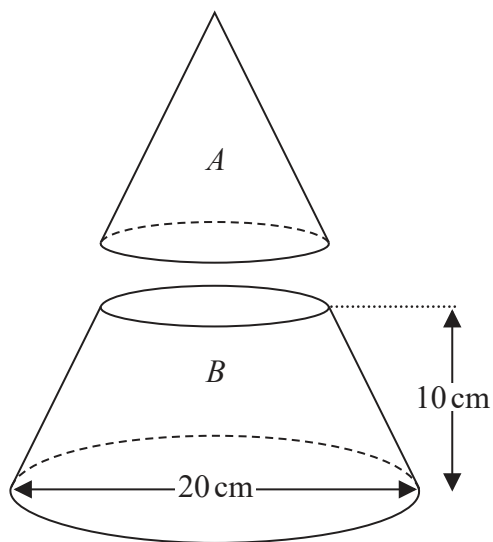

The shape *B* is formed from cone *S* by cutting *S* parallel to its base and removing cone *A*, as shown in the diagram above.

The height of *B* is 10 cm.

(b) Calculate the volume, in cm^3 to 3 significant figures, of *B*.

..... cm^3
(3)

(Total for Question 22 is 5 marks)



- 23 The incomplete histogram and the incomplete table give information about the daily mean temperature for 184 days measured at Heathrow. None of the daily mean temperatures were less than 5°C and all the daily mean temperatures were less than 25°C .

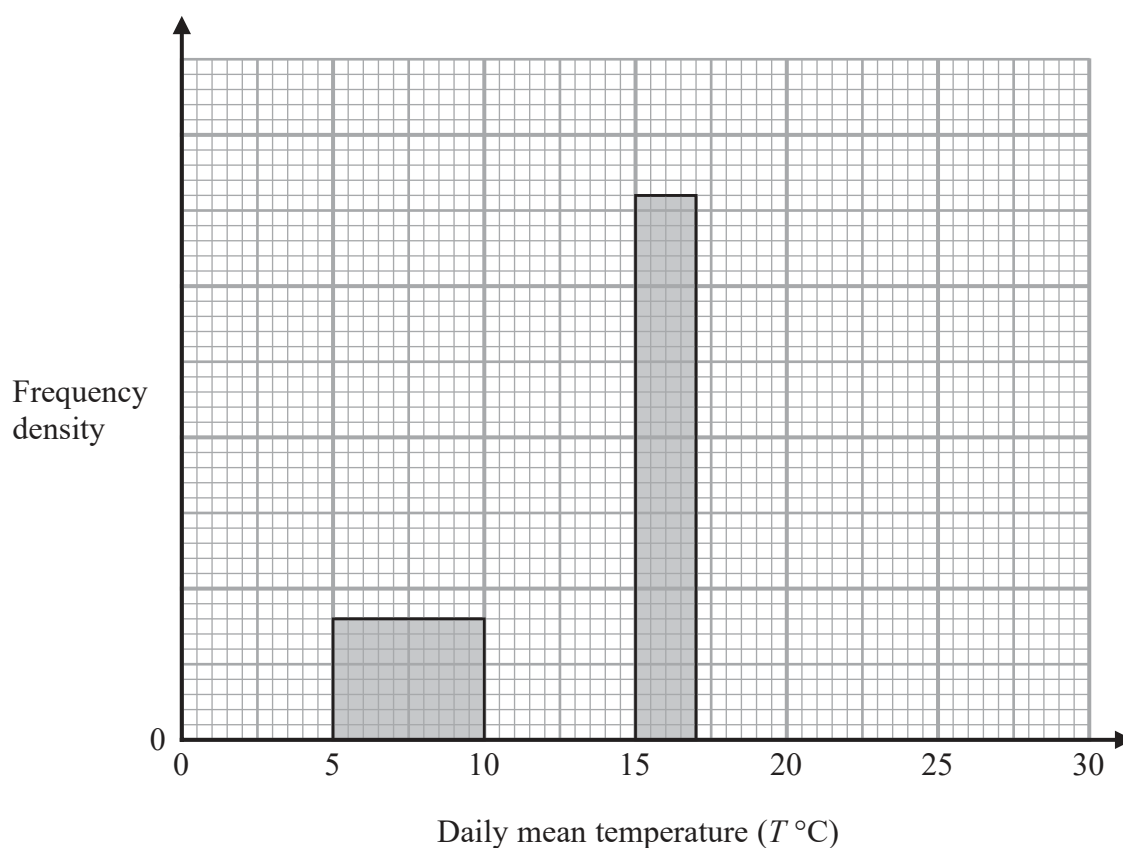

Daily mean temperature ($T^{\circ}\text{C}$)	Number of days
$5 \leq t < 10$	20
$10 \leq t < 15$	80
$15 \leq t < 17$	
$17 \leq t < 25$	

Complete the histogram and the table.

(Total for Question 23 is 5 marks)



24 The functions f and g are defined as

$$f : x \mapsto x - 3$$

$$g : x \mapsto x^2 - 2$$

(a) Find $fg(6)$

.....
(2)

The function h is defined as

$$h(x) = gf(x)$$

(b) Show that $h(x) = x^2 - 6x + 7$

.....
(2)

The domain of h is $\{x : x \geq n\}$

The inverse of h is h^{-1}

(c) State the least value of n for which h^{-1} is a function.

$$n = \text{.....}$$

(1)

(d) For this value of n , find $h^{-1}(x)$

$$h^{-1}(x) = \text{.....}$$

(3)

(Total for Question 24 is 8 marks)



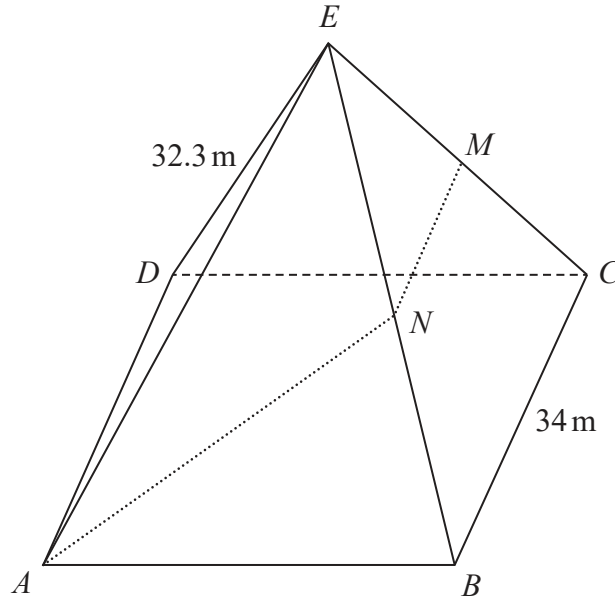

Diagram **NOT** accurately drawn

DO NOT WRITE IN THIS AREA

DO NOT WRITE IN THIS AREA

DO NOT WRITE IN THIS AREA

The diagram shows a solid right pyramid $ABCDE$ with a square base $ABCD$ on a horizontal plane. The vertex E of the pyramid is vertically above the centre of the base.

$$BC = 34\text{ m} \quad EA = EB = EC = ED = 32.3\text{ m}$$

The point M is the midpoint of CE and the point N is the midpoint of BE .

Given that $AN + NM = x$ metres

(a) calculate the value, to 2 significant figures, of x .

$x = \dots\dots\dots$

(6)



(b) Calculate the size, to the nearest degree, of angle BAN .

DO NOT WRITE IN THIS AREA

DO NOT WRITE IN THIS AREA

DO NOT WRITE IN THIS AREA

.....
(2)

(Total for Question 25 is 8 marks)

Turn over for Question 26



- 26 A particle P is moving along a straight line. At time t seconds, the displacement, s metres, of P from a fixed point O on the line is given by

$$s = 5t^2 - t^3 \quad 0 \leq t \leq 5$$

At time T seconds, where $T > 0$, P comes to instantaneous rest.

- (a) Find the exact value of T .

$$T = \dots\dots\dots (4)$$

- (b) Find the total distance travelled by the particle between $t = 0$ and $t = 5$

$$\dots\dots\dots \text{ m} \quad (3)$$

(Total for Question 26 is 7 marks)

TOTAL FOR PAPER IS 100 MARKS

